

The KESTX01 and KESTX02 are designed for use in the 290-470MHz region, with a push-pull output stage designed to reduce second harmonic emissions when a suitable balanced output circuit is used. There is a requirement for low power transmitters operating in the 900MHz region, and this can be met with the KESTX01 and KESTX02 by connecting the push pull outputs together and using the output stage as a 'push-push doubler' - a well known technique with tubes in the 1930's.

The circuit arrangement used for evaluation is shown in Fig. 1. For each supply voltage, the optimum load impedance was achieved by the use of the 2 stub tuner, and the output power at the various unwanted frequencies was measured with a spectrum analyser - Tables 1 and 2.

Table 1: output powers, (spurious and wanted), optimum load and supply voltage for 917MHz wanted output

458.5MHz	917MHz	1374MHz	1834MHz	Optimum load (ohms)	V supply volts
-37.5dBm	-16.5dBm	-52dBm	-55dBm	12.5 + j20	3.0
-38dBm	-5.5dBm	-50dBm	-29dBm	5.5 + j9	3.5
-38dBm	-6dBm	-50dBm	-30dBm	4.5 + j6	4.0
-36dBm	-3dBm	-50dBm	-33dBm	6 + j10	4.5
-40dBm	-2dBm	-45dBm	-24dBm	6.5 + j10	5.0
-36dBm	-3dBm	-48dBm	-25dBm	7 + j12	5.5
-34dBm	-1.5dBm	-44dBm	-27dBm	8 + j11	6.0
-36dBm	-1dBm	-46dBm	-25dBm	8.5 + j8.5	6.5
-37dBm	-2dBm	-47dbm	-25dBm	7.5 + j10	7.0
-40dBm	-1dBm	-44dBm	-24dBm	7 + j7	7.5

Table 2: output powers, (spurious and wanted), optimum load and supply voltage for 867.2MHz wanted output

433.6MHz	867.2MHz	1300MHz	1734MHz	Optimum load (ohms)	V supply volts
-39dBm	-15dBm	-51dBm	-48dBm	19 + j17	3.0
-38dBm	-7dBm	-50dBm	-34dBm	9 + j16	3.5
-38dBm	-3dBm	-40dBm	-27dBm	6 + j15	4.0
-36dBm	-3dBm	-40dBm	-28dBm	9 + j23	4.5
-35dBm	-3dBm	-41dBm	-28dBm	9 + j22	5.0
-35dBm	-2dBm	-42dBm	-31dBm	12 + j21	5.5
-34dBm	-2dBm	-45dBm	-33dBm	14 + j22	6.0
-34dBm	-2dBm	-40dBm	-29dBm	17 + j30	6.5
-32dBm	-2dBm	-39dBm	-33dBm	17 + j20	7.0
-29dBm	-2dBm	-40dBm	-35dBm	20 + j20	7.5

These results show that operation with low powers at these frequencies is practical; However, some additional antenna selectivity will be required to meet regulatory requirements (-42dBm EIRP)

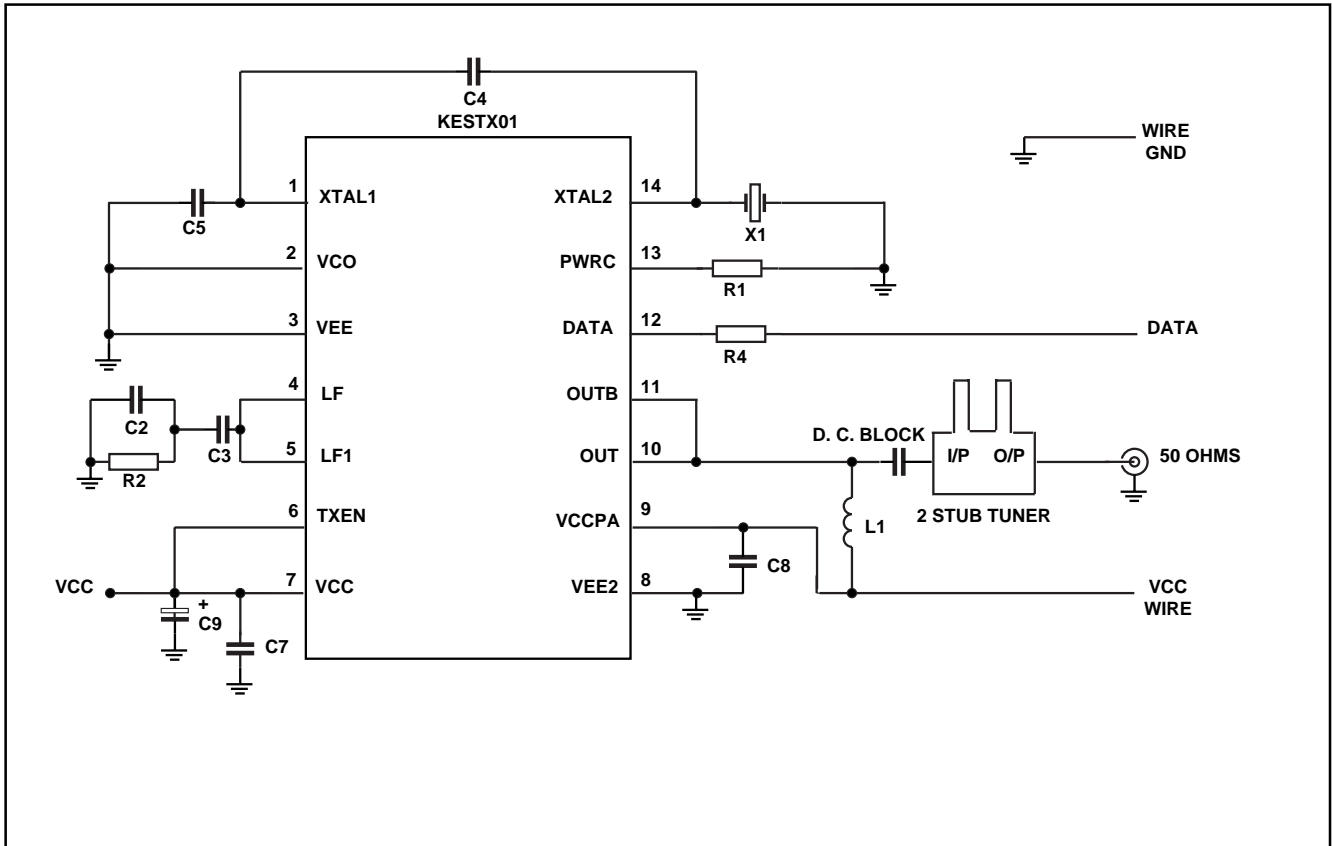

Fig. 1 KESTX01/02 at 900MHz

Component List

C2	3.9nF	R1	2K
C3	22nF	R2	820
C4	18pF	R4	4.7k
C5	18pF	TXENLINK	0Ω
C8	1μF	L1	82nH
C9	10μF	D.C. Block	100pF



HEADQUARTERS OPERATIONS

MITEL SEMICONDUCTOR

Cheney Manor, Swindon,
Wiltshire SN2 2QW, United Kingdom.
Tel: (01793) 518000
Fax: (01793) 518411

MITEL SEMICONDUCTOR

1500 Green Hills Road,
Scotts Valley, California 95066-4922
United States of America.
Tel (408) 438 2900
Fax: (408) 438 5576/6231

Internet: <http://www.gpsemi.com>

CUSTOMER SERVICE CENTRES

- **FRANCE & BENELUX** Les Ulis Cedex Tel: (1) 69 18 90 00 Fax : (1) 64 46 06 07
- **GERMANY** Munich Tel: (089) 419508-20 Fax : (089) 419508-55
- **ITALY** Milan Tel: (02) 6607151 Fax: (02) 66040993
- **JAPAN** Tokyo Tel: (03) 5276-5501 Fax: (03) 5276-5510
- **KOREA** Seoul Tel: (2) 5668141 Fax: (2) 5697933
- **NORTH AMERICA** Scotts Valley, USA Tel: (408) 438 2900 Fax: (408) 438 5576/6231
- **SOUTH EAST ASIA** Singapore Tel:(65) 3827708 Fax: (65) 3828872
- **SWEDEN** Stockholm Tel: 46 8 702 97 70 Fax: 46 8 640 47 36
- **TAIWAN, ROC** Taipei Tel: 886 2 25461260 Fax: 886 2 27190260
- **UK, EIRE, DENMARK, FINLAND & NORWAY**
Swindon Tel: (01793) 726666 Fax : (01793) 518582

These are supported by Agents and Distributors in major countries world-wide.

© Mitel Corporation 1998 Publication No. AN4807 Issue No. 1.5 January 1998

TECHNICAL DOCUMENTATION – NOT FOR RESALE. PRINTED IN UNITED KINGDOM

This publication is issued to provide information only which (unless agreed by the Company in writing) may not be used, applied or reproduced for any purpose nor form part of any order or contract nor to be regarded as a representation relating to the products or services concerned. No warranty or guarantee express or implied is made regarding the capability, performance or suitability of any product or service. The Company reserves the right to alter without prior notice the specification, design or price of any product or service. Information concerning possible methods of use is provided as a guide only and does not constitute any guarantee that such methods of use will be satisfactory in a specific piece of equipment. It is the user's responsibility to fully determine the performance and suitability of any equipment using such information and to ensure that any publication or data used is up to date and has not been superseded. These products are not suitable for use in any medical products whose failure to perform may result in significant injury or death to the user. All products and materials are sold and services provided subject to the Company's conditions of sale, which are available on request.

All brand names and product names used in this publication are trademarks, registered trademarks or trade names of their respective owners.